

**Draft Cost Estimation Manual**  
**for Road Maintenance Works**  
**Upper Eastern Region**  
Fourth Revised Edition | April 2025

**COST ESTIMATION MANUAL  
FOR ROAD MAINTENANCE WORKS**

© Government of Kenya

First Edition, 2011

Second Revised Edition, 2019

Third Revised Edition, 2022

Fourth Revised Edition, 2025

Nairobi

# Contents

Acknowledgement.....	i
Abbreviations and Acronyms.....	iii
Glossary of Terms .....	v
1. Introduction .....	1
1.1. Purpose of the Manual.....	1
1.2. Application of the Manual.....	1
2. Contents of the Manual .....	2
2.1. Work items and coding.....	2
2.2. Cost configuration .....	2
2.3. Price list and source.....	3
2.4. Haulage cost .....	6
2.5. Unit quantity and productivity .....	8
2.6. Indirect work costs.....	8
2.7. Overheads and Profit.....	8
2.8. Revision Highlights.....	9
3. Unit Rates List.....	11
APPENDICES .....	19
Appendix 1 – Work Items .....	20
Appendix 2 – Price List.....	21



# Acknowledgement

Kenya Roads Board through the Director General, Rashid Mohamed, MBS, would like to express sincere gratitude to the Inter-Agency Cost Estimation Task Force for its initiative towards the update and publication of the Cost Estimation Manual, 2025. In particular, gratitude goes to the Kenya Roads Board Project Implementation Team led by the Director Policy and Planning, Eng. Tom Omai, Deputy Director Policy and Planning, Eng. Victor Odula, Deputy Project Manager, Thomas Bundi, assisted by Eng. Tabitha Kariuki.

We further extend special thanks to the following Road Agencies and organisations that participated in the Cost Estimation 2025 validation workshop:

Chief Engineer Roads, State Department of Roads

Kenya National Highways Authority (KeNHA)

Kenya Urban Roads Authority (KURA)

Kenya Rural Roads Authority (KeRRA)

Kenya Wildlife Services (KWS)

This Manual would not have come to fruition without the dedication and the technical support provided by the Consultant, M/s ITEC Engineering Ltd.

Finally, we wish to acknowledge and thank the team from the Chief Engineer Roads and Road Authorities that were involved in Cost Estimation validation workshop for their valuable contributions.



# Abbreviations and Acronyms

<b>AASHTO</b>	American Association of State Highway and Transportation Officials
<b>AC</b>	Asphalt Concrete
<b>CBR</b>	California Bearing Ratio
<b>JICA</b>	Japan International Cooperation Authority
<b>KeNHA</b>	Kenya National Highways Authority
<b>KeRRA</b>	Kenya Rural Roads Authority
<b>KNBS</b>	Kenya National Bureau of Statistics
<b>KRB</b>	Kenya Roads Board
<b>KURA</b>	Kenya Urban Roads Authority
<b>KWS</b>	Kenya Wildlife Service
<b>MDD</b>	Maximum Dry Density
<b>MoTIHUD &amp; PW</b>	Ministry of Transport, Infrastructure, Housing, Urban Development and Public Works
<b>MTD</b>	Mechanical and Transport Division
<b>PPRA</b>	Public Procurement Regulatory Authority
<b>PVC</b>	Polyvinyl Chloride
<b>RAs</b>	Road Agencies / Authorities
<b>RMS</b>	Road Management System
<b>VAT</b>	Value-added Tax





# Glossary of Terms

<b>Abutment</b>	Structure support to bridge deck and retains the road embankment.
<b>Adhesion</b>	Sticking quality, for example, holding aggregate to the binder in chip sealing.
<b>Aggregate</b>	Crushed local rock or stone.
<b>Apron</b>	Floor of concrete, masonry or stone at the inlet or outlet of a culvert or waterway to prevent scour.
<b>Asphalt Concrete</b>	Road construction material usually comprising a mixture of bitumen and aggregate, also known as hot-mix or hot-rolled asphalt.
<b>Base Course</b>	The main structural element of the pavement, between the surface course and subbase.
<b>Benching</b>	A stepped platform cut in an embankment to prevent earth slipping and improve slope stability. Can also be used as a stepping to provide a level base for additional fill material.
<b>Berm</b>	A low ridge or bund of soil to collect or redirect surface water.
<b>Binder</b>	An adhesive material, usually bitumen or bitumen emulsion, used to seal the road surface, also providing a waterproof layer to receive and hold aggregate. The most common binders are bitumen based. A binder is also used to hold aggregate together in bituminous mixtures.
<b>Binder Course</b>	The layer forms part of the bituminous surfacing immediately below the wearing course.
<b>Bitumen</b>	Bitumen (called asphalt cement in the US) is a black to dark brown sticky material composed principally of high-molecular-weight hydrocarbons. Most bitumen is derived from the distillation of crude oil. Bitumen is a thermoplastic material that gradually liquefies when heated.
<b>Borrow Pit</b>	An excavation outside the road limits from which suitable material is obtained, usually for earthwork or re-gravelling operations.
<b>Box Culvert</b>	A culvert of rectangular cross-section, usually constructed in reinforced concrete.

<b>Bridge</b>	A structure with a span of 6 metres or more providing a means of transit above land and/or water or above an obstruction, whether natural or artificial.
<b>Camber (Cross Fall)</b>	The transverse slope applied to the carriageway on a section of straight alignment.
<b>Causeway</b>	Low-level structure constructed across streams or rivers with openings to permit water to pass below road level.
<b>Carriageway</b>	The part of the road used by vehicular traffic.
<b>Catchment Area</b>	The area from which water runs off by gravity to a collecting point.
<b>Catch pit</b>	A covered, accessible chamber with a sump for collection of silt forming part of the drainage system and permitting inspection and maintenance of underground drainage pipes.
<b>Centre-line</b>	The middle of the carriageway, normally marked with a yellow dashed line on a paved road.
<b>Compaction</b>	Compacting embankment by roller to increase the density of soil what composes embankment body. It causes to improve mechanical properties of soil.
<b>Cross-fall</b>	The transverse gradient or fall across a formation or pavement.
<b>Cross-section</b>	Section through the road construction at right angles to the centre-line.
<b>Crown</b>	The highest part of a cambered surface, usually on or near the centre-line.
<b>Culvert</b>	A duct, usually rectangular or circular, for carrying surface water under the road.
<b>Cut (Cutting)</b>	Excavation in natural ground usually with graded slopes.
<b>Cut-off Drain</b>	A drain cut to intercept surface water flowing from adjacent land and to prevent it reaching a pavement or other prepared surface.
<b>Cut Slope</b>	A soil plane constructed at an angle to the horizontal.
<b>Cycleway</b>	The track which is mainly used for bicycle traffic. The track is separated with other parts of road by kerb stone or its similar structures.
<b>Ditch (Drain)</b>	A long narrow excavation designed or intended to collect and drain off surface water.
<b>Drainage</b>	The interception and removal of ground and surface water by artificial or natural means.

<b>Drainage Channel</b>	A waterway or gutter to carry away surface water.
<b>Drift or Ford</b>	A stream or river crossing at bed level over which the stream or river water can flow.
<b>Earthworks</b>	General term of construction works involving soil and rocks (e.g. excavation, loading, hauling, spreading and compaction).
<b>Embankment Slope</b>	An artificially constructed soil plane at an angle to the horizontal.
<b>Fill (Embankment)</b>	Earthworks constructed below the pavement raising the road above the surrounding natural ground level.
<b>Footbridge</b>	The overpass bridge crossing carriageway/railway to ensure the safety of pedestrian and smooth vehicle traffic.
<b>Footpath</b>	The track which is mainly used for pedestrian. The track is separated with other parts of road by kerb stone or its similar structures.
<b>Gabion</b>	The steel mesh cage filled with cobble stone or crushed stone. This is mainly used for revetment and foot protection.
<b>Gravel</b>	A non-cohesive, coarse granular material, resulting from natural disintegration of rock with or without finer material. In general, the particles are irregular or flaky. It is used as material of surface course and to correct loss of shape, ruts, potholes and erosion gullies.
<b>Guardrail</b>	A safety barrier on embankment or river crossing
<b>Gutter</b>	A shallow waterway provided at the edge of the road to carry surface water longitudinally.
<b>Headwalls</b>	The walls located on the top of outlet/inlet of culvert. The walls of inlet direct the flow into the culvert, while the walls of outlet provide a transition from the culvert to the outlet channel. Headwalls also protect the embankment from erosion by flood waters.
<b>Inlet</b>	The point at which surface water enters a pipe culvert or box culvert.
<b>Invert</b>	The lowest point of the internal cross section of a ditch or culvert.
<b>Lane</b>	The width of carriageway required to accommodate one line of traffic.

<b>Manhole</b>	Accessible chamber with a cover forming part of the drainage system and permitting inspection and maintenance of underground drainage pipes.
<b>Mitre Drain</b>	Short, open, skew ditches used to remove water from the roadside ditches or gutters. Use of this reduces the necessary size of the side ditches and minimizes the velocity of water and thereby the risk of erosion.
<b>Original Ground Level</b>	Line of natural ground.
<b>Outfall</b>	The point at which water discharges from a pipe or box culvert.
<b>Paved Road</b>	For the purpose of this manual a paved road is a road with a concrete surface, concrete block, bituminous surface or surface dressing.
<b>Pavement</b>	The road structure above the formation, designed to spread the loading over the base and subbase.
<b>Pipe Culvert</b>	A culvert of circular cross-section, usually constructed in pre-cast concrete.
<b>Premix</b>	Premix is a paving material manufactured by mixing aggregates, filler and bitumen. Most premix is mixed and placed hot. Premix is used in the construction of wearing course, binder courses and base courses.
<b>Prime Coat</b>	A coating of low viscosity binder applied to a surface of stabilised or naturally compacted soil before sealing or paving.
<b>Road Reserve (Right-of-way)</b>	The area within the road limits over which members of the public have the right to pass and re-pass.
<b>Road Furniture</b>	Road or street furniture e.g., traffic sign, traffic board, traffic signal, lane marking, guardrail, street light, etc.
<b>Roadway</b>	The portion of a road including shoulders for vehicular use.
<b>Scour Checks</b>	The structures to prevent scouring of drains. Simple scour checks may be constructed of wood pegs or stones. All scour checks should have an apron downstream built of stones or grass turves pinned to the ditch invert with wooden pegs.
<b>Shoulder</b>	Paved or unpaved part of the road next to the outer edge of the pavement. The shoulder provides side support for the pavement and allows vehicles to stop or pass in an emergency.
<b>Side Drain</b>	Drain beyond the shoulders, parallel to the centre-line, to take the run-off from the road surface.

<b>Slope</b>	A natural or artificially constructed soil plane at an angle to the horizontal.
<b>Sub-base</b>	The layer of material between the base course and the subgrade.
<b>Subgrade</b>	Upper layer of the soil that supports the pavement
<b>Superelevation</b>	Raising outside edge level of the road above the inner edge level on curves to reduce the effect of centrifugal forces and minimize sliding, skidding, tipping and rolling over of vehicles through curves.
<b>Surfacing</b>	Top layer of the pavement. Consists of wearing course, and sometimes a base course or binder course.
<b>Surface Dressing</b>	A sprayed or hand-applied film of bitumen followed by the application of a layer of stone chippings, which is then rolled.
<b>Tack Coat</b>	Asphalt material to bond lower layer (asphalt material or cement) and upper layer (asphalt mixture). It is sprayed on surface of lower layer.
<b>Traffic Lane</b>	The portion of the carriageway defined by road marking for the movement of a single line of vehicles.
<b>Transverse Joint</b>	Joint at right angles to the road centre-line.
<b>Transverse Joint Taper</b>	Slope or ramp of asphalt mix at the end of a freshly laid asphalt course.
<b>Unpaved Road</b>	For the purpose of this manual an unpaved road is a road with a gravel or earth surface.
<b>Wearing Course</b>	The part of the road surface in contact with traffic wheels.
<b>Wing-wall</b>	Retaining wall at a bridge abutment to retain and protect the embankment fill behind the abutment.

## Cross Section

The typical cross sections of paved, unpaved and urban roads are as follows:

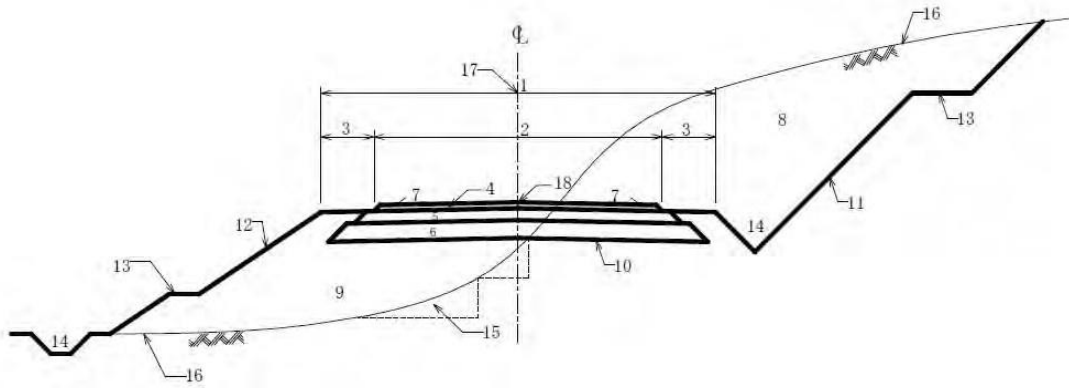

**Paved Road**

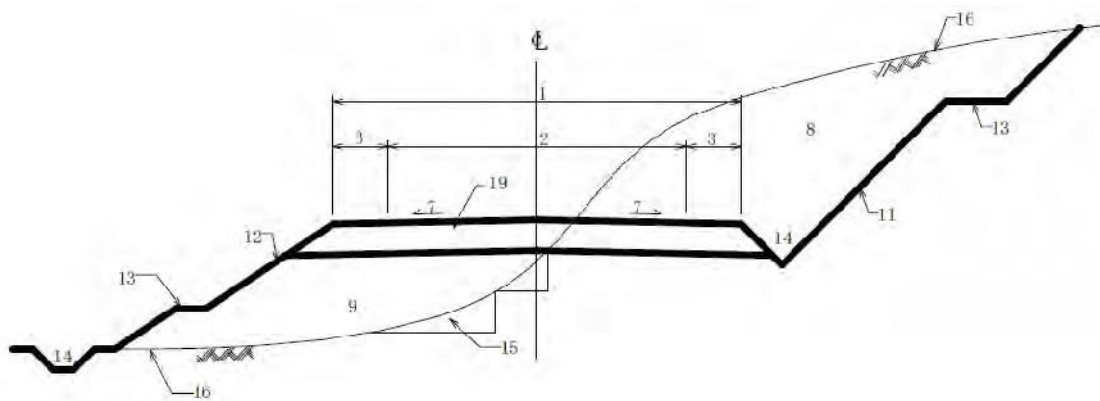

**Unpaved Road**

- |                          |                        |                |                    |              |
|--------------------------|------------------------|----------------|--------------------|--------------|
| 1. Roadway               | 2. Carriageway         | 3. Shoulder    | 4. Surfacing       | 5. Base      |
| 6. Sub-base              | 7. Camber (Cross Fall) | 8. Cut         | 9. Embankment      | 10. Subgrade |
| 11. Cut Slope            | 12. Embankment Slope   | 13. Berm       | 14. Side Ditch     | 15. Benching |
| 16. Natural Ground Level | 17. Centre-line        | 18. Marking    | 19. Gravel         | 20. Footpath |
| 21. Road Reserve         | 22. Pavement           | 23. Side Ditch | 24. Boundary Stone |              |

# I. Introduction

The Kenya Vision 2030 is the long-term vision which aspires that Kenya becomes a globally competitive and prosperous country by the year 2030. The plan is anchored on three pillars: The Economic, the Social and the Political. Infrastructure is considered one of the foundations and enablers of macroeconomic stability to support the three main pillars. The 2025 edition of the Cost Estimation Manual (CEM) for Road Maintenance Works builds upon Kenya's commitment to sustainable infrastructure development as outlined in the Kenya Vision 2030 and the ongoing Fourth Medium Term Plan (MTP IV) 2023–2027. As infrastructure continues to serve as a key enabler of economic growth and social transformation, the roads sub-sector plays a central role.

Originally developed in 2011 by the Ministry of Transport, Infrastructure, Housing, Urban Development and Public Works (MoTIHUD&PW) with support from the Japan International Cooperation Agency (JICA), the CEM has undergone several revisions—in 2017, 2019, and most recently in 2022—to align with technological advancements, market trends, and evolving construction practices. The 2025 edition consolidates these updates and introduces refinements to ensure the manual remains responsive to current industry needs, while promoting transparency, efficiency, and value for money in road maintenance investments.

## I.1. Purpose of the Manual

The 2025 CEM is intended to provide a standardized, transparent, and data-driven approach to estimating the cost of road maintenance works in Kenya. By promoting consistency and predictability in cost estimation, the manual helps improve accountability and decision-making in the roads sector. It serves as a practical guide for engineers, contractors, road agencies, and procurement entities by:

- Defining cost elements and unit rates based on realistic inputs and methodologies.
- Supporting the preparation of consistent, accurate, and defensible estimates.
- Facilitating fair competition during procurement through reliable benchmarking.
- Informing the planning and budgeting of maintenance works at national and county levels.

## I.2. Application of the Manual

The manual is to be used throughout the project cycle, with specific application in the following areas:

- Preparation of Engineer's Estimates for tendering by procurement entities, serving as a baseline for evaluating bids.
- Development of annual and medium-term maintenance plans by Road Agencies and County Governments.
- Project auditing and monitoring using benchmarking costs for ongoing and completed works to assess value for money and compliance.
- Bidding support for contractors and consultants to prepare competitive bids aligned with sector-wide cost standards.

# 2. Contents of the Manual

## 2.1. Work items and coding

The work items covered in this manual are listed in Appendix I. These represent the common categories of activities frequently encountered in road maintenance works across Kenya. Each work item has been structured to reflect standardised practices and operational realities in the sector.

The coding of work items follows the Road Management System (RMS) and is aligned with the classification in the Standard Specifications for Road and Bridge Construction (1986).

## 2.2. Cost configuration

Road works consist of a combination of individual work items that are aggregated into work packages. The total cost of any work package is structured in the formula shown in Figure 2-1 below which incorporates all direct and indirect cost elements.

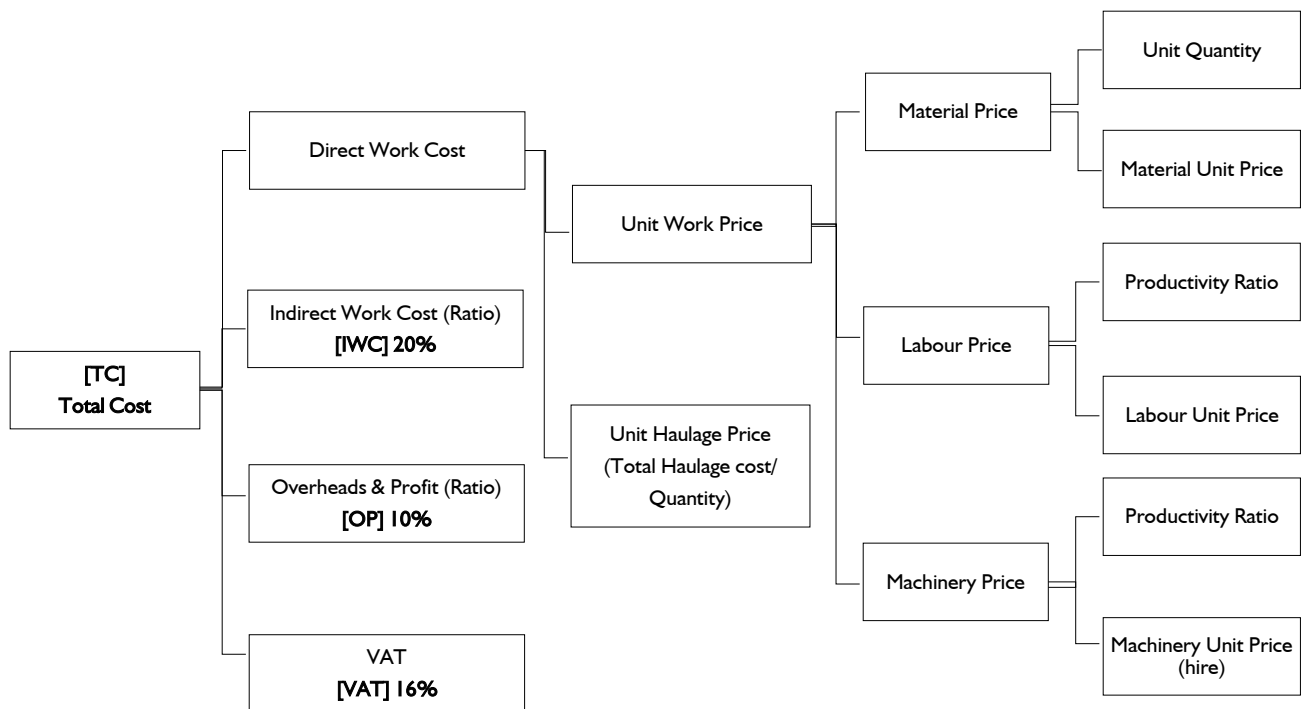

Figure 2-1: Cost configuration

$$TC = \sum (Q \times UP) \times (1 + IWC) \times (1 + OP) \times (1 + VAT)$$



Where:

Q = Quantity of each work item

UP = Unit Price (combination of Unit Work Price and Unit Haulage Price)

IWC = Indirect Work Cost ratio

OP = Overheads and Profit ratio

VAT = Value Added Tax as per prevailing tax laws

Direct Work Costs represent the actual input costs required for the execution of each activity, including materials, labour, and equipment. These are computed as the product of the quantity and the unit price. Unit Price comprises the Unit Work Price (assuming all resources are on-site) and the Unit Haulage Price, which accounts for transportation.

Indirect Work Costs cover the administration, management, and logistical support required to execute the works and are applied as a percentage of Direct Work Costs.

Overheads and Profits are also expressed as a ratio of Direct Work Costs, while VAT is applied as per current statutory rates.

## 2.3. Price list and source

Unit prices for materials, labour, and machinery used in cost estimation are primarily drawn from official government price indices and are considered reflective of nationwide average market conditions. These are regularly reviewed and made publicly accessible. The key sources include:

- **Material Prices:** Sourced from the Kenya National Bureau of Statistics (KNBS).
- **Labour Rates:** Based on the Regulation of Wages (General) (Amendment) Order and The Labour Institutions Act under the Ministry of Labour.
- **Machinery Hire Rates:** Derived from the Equipment Hire Rate List issued by the Mechanical and Transport Division (MTD) under the Ministry.

In this 2025 CEM revision, unit rates were regionally disaggregated into ten (10) geographical zones to account for cost variations across the country.

Official prices are updated periodically, and ad-hoc adjustments may be made in response to significant market shifts such as inflation spikes, supply disruptions, or policy changes. In cases where official prices are outdated or unavailable, market surveys or comparable benchmarks may be used to derive provisional estimates. These are to be revised as soon as official data becomes available.

All prices and rate components are codified using the RMS coding system to ensure uniformity in cost estimation and project reporting. Details of current unit prices and their respective sources are provided in Appendix 2.

## Selection of the Survey Areas

For the development of the 2025 Cost Estimation Manual (CEM), survey areas were strategically selected to ensure comprehensive national coverage and representation of diverse geographic, economic, and infrastructural conditions. A total of ten (10) regions were identified jointly by the Consultant and the Kenya Roads Board (KRB) team. These regions reflect Kenya's key road maintenance zones and were used to capture variations in material availability, labour costs, equipment access, terrain, and climatic conditions.

In total, seventy (70) towns and cities across the ten regions were surveyed. This broad and balanced selection provides a reliable data foundation for deriving regionalised unit rates, ensuring that the manual reflects actual market conditions and supports realistic and equitable budgeting.



Figure 2-2: Market Survey Locations

Source map: Consultant

## Survey Methods

To ensure the reliability and accuracy of the 2025 Cost Estimation Manual (CEM), both primary and secondary data collection methods were employed. The approach was designed to capture prevailing market conditions while incorporating official benchmarks for national consistency.

### Primary Data Collection

In each of the selected cities/towns, information was gathered through visits to: wholesale suppliers, major hardware shops, warehouses, road contractors, items manufacturers etc.

Additionally, online market surveys were carried out using publicly available price lists. These were verified during field visits to ensure consistency with actual market prices.

### Secondary Data Collection

Recognised official sources were used to supplement and validate the field data. These sources provided baseline rates to be used where market data was inconsistent, outdated, or unavailable.

## Unit Price Analysis

### Labour

Contractors were selected based on prior road agency project experience. Labour unit rates were primarily obtained from these contractors. However, where market rates were lower than the government-mandated minimums, the Regulation of Wages (General) (Amendment) Order, 2024 was applied to ensure compliance.

Priority	Survey Data Source	Target Trade
1.	Contractor	Road Construction
2.	Documented Labour Law	Building and Construction

### Material

Suppliers were selected randomly, based on material availability and accessibility. Data collection was conducted through field visits, phone interviews, emails, internet research, and recommendations from contractors and Road Agencies.

The procedure to determine the unit price is as follows:

1. Market survey prices were prioritised.
2. Prices were collected from at least three suppliers and averaged.
3. Outlier prices (too low or too high) were excluded from the average.
4. If the item was unavailable in the current market, the 2022 rate was adjusted and used.
5. Where the updated rate varied significantly from the 2022 value, all available data sources were reviewed, and the most reasonable figure was adopted.

Priority	Source of Data
1.	Market Survey
2.	Kenya National Bureau of Statistics (KNBS)
3.	Road Authorities e.g. KeNHA, KURA, KeRRA

#### Equipment

Suppliers of equipment hire services were identified through online research and recommendations from Road Agency regional offices and contractors. Market survey rates were prioritised, but official rates from the Mechanical and Transport Division (MTD) were used where necessary.

Priority	Source of Data
1.	Market Survey
2.	Mechanical and Transport Division (MTD)

## 2.4.Haulage cost

The location of a project site significantly influences the unit cost of work due to transportation expenses. Accordingly, haulage costs must be carefully estimated as they form a key component of the total cost.

In this manual, haulage costs are calculated using a standardized approach as outlined in Table 2-1, which considers the operating costs of transport vehicles (both dry hire and fuel), driver and turn boy wages, distance, and number of trips.

The total haulage cost is divided by the quantity of the material or equipment transported and added to the unit work price, forming the complete unit cost of the work item. Where a verifiable and current haulage quotation is available, it may be used in place of the manual's estimation formula.

Table 2-1: Estimation of Haulage Price

Type of Vehicle:	(specify)	
Vehicle price per hour (or dry hire rate) = A		Ksh/hr
Fuel price per hour, $B = C/D * E$		Ksh/hr
Fuel cost per litre = C		Ksh/litre
Fuel consumption rate = D		km/litre
Average speed during transport = E		km/hr
Driver wage per hour, $F = G/8hr$		Ksh/hr
Wage per day = G		Ksh/day
Turn boy wage per hour, $H = I/8hr$		Ksh/hr
Wage per day = I		Ksh/day
<b>Total price per hour of transport, <math>J = A+B+F+H</math></b>		Ksh/hr
<b>Distance of transport (one way) = K</b>		km
<b>Frequency of transport (no. of round trip) = L</b>		times
Distance of transport (by round trip), $M = 2 * K$		km
Total Distance of transport, $N = L * M$		km
<b>Total time of Transport, <math>O = N/E</math></b>		hr
<b>Total Haulage Price, <math>P = J * O</math></b>		Ksh

## 2.5. Unit quantity and productivity

To compute accurate cost estimates, unit quantities and productivity rates for materials, labour, and machinery must be clearly defined:

- Unit quantity refers to the amount of material required per unit of work.
- Labour productivity is the amount of labour effort (e.g., person-hours) needed per unit of work.
- Machinery productivity is the operational time (e.g., machine-hours or days) required per unit of work.

The sources used to determine these quantities and productivity benchmarks include:

- The Standard Specifications for Road and Bridge Construction (1986) by the Ministry of Transport and Communications;
- Official standard drawings; and,
- Average rates obtained from site surveys and past engineering experience, including technical input from JICA.

## 2.6. Indirect work costs

Indirect work costs represent expenses that are not directly attributable to specific work items but are essential to project execution. These include:

- Human Resource Management costs (recruitment, welfare, insurance, transport, uniforms);
- Site staff allowances;
- Site-level management and administration (office setup, utilities, communication);
- Implementation of occupational safety and health measures; and,
- Social charges (local taxes, public fees, staff welfare costs).

These costs are incorporated as a ratio of direct work costs in the cost configuration model.

## 2.7. Overheads and Profit

Overheads and profit reflect costs incurred at the organizational level, as well as the contractor's expected return. These include:

- Head office salaries and allowances;
- Corporate administration and support services;
- Company-level social charges (insurance, taxes, and staff welfare);
- Research, development, and innovation;
- Marketing and publicity activities;
- Depreciation of company assets and facilities; and,

- Profit margin (bonuses, shareholder dividends, and retained earnings).

Given the variability and complexity in estimating these figures precisely, a standardised ratio to the total direct work cost is applied to account for these elements in the overall cost estimation.

## 2.8.Revision Highlights

2011	
	<ol style="list-style-type: none"> <li>1. Developed and published using Japanese productivity rates for labour, machinery and materials multiplied by a factor.</li> <li>2. Unit rates used are for only two regions i.e. Nairobi, Mombasa and Kisumu as one region and “all other areas” as the other.</li> <li>3. Unit prices were obtained from the Kenyan market.</li> </ol>
2017	
	<ol style="list-style-type: none"> <li>1. Update of Unit prices for Nairobi, Mombasa and Kisumu and All other areas.</li> <li>2. Update of quantities for the following work items: <ul style="list-style-type: none"> <li>– Gabion Installation; and,</li> <li>– Pothole Repair.</li> </ul> </li> <li>3. Miscellaneous costs are adjusted as follows: <ul style="list-style-type: none"> <li>– 20% for Concrete works, Structural Works and complicated street furniture works reduced to 10%; and,</li> <li>– 10% for Clearing, cleaning, earthwork, base and surfacing works and simple street furniture works reduced to 5%.</li> </ul> </li> </ol>
2019	
	<ol style="list-style-type: none"> <li>1. Update of unit prices for Nairobi, Mombasa and Kisumu.</li> <li>2. Update of unit rate calculation tables for the following: <ul style="list-style-type: none"> <li>– Labour-based works: Ditch cleaning (Manual) and culvert cleaning;</li> <li>– On-carriageway works including pothole repair, headwall repair, re-gravelling and road marking; and,</li> <li>– Cement/ lime mixing.</li> </ul> </li> <li>3. Addition of guardrail repair.</li> <li>4. Indirect costs were reduced from 30% to 20%.</li> </ol>
2022	
	<ol style="list-style-type: none"> <li>1. Update of unit prices collected from eight (8) regions (19 towns and 3 cities) i.e. Nairobi/ Central, Coast, Nyanza/Western, North Rift, South Rift, Upper Eastern, Lower Eastern and North Eastern.</li> <li>2. Update of productivity rates for the following equipment: <ul style="list-style-type: none"> <li>– Water tanker;</li> <li>– Motor grader; and,</li> <li>– Pneumatic roller.</li> </ul> </li> </ol>
2025	
	<ol style="list-style-type: none"> <li>1. Update of unit prices collected from ten (10) regions (5 cities and 65 towns) i.e. Nairobi, Central, Coast, Nyanza, Western, North Rift, South Rift, Upper Eastern, Lower Eastern and North Eastern.</li> </ol>

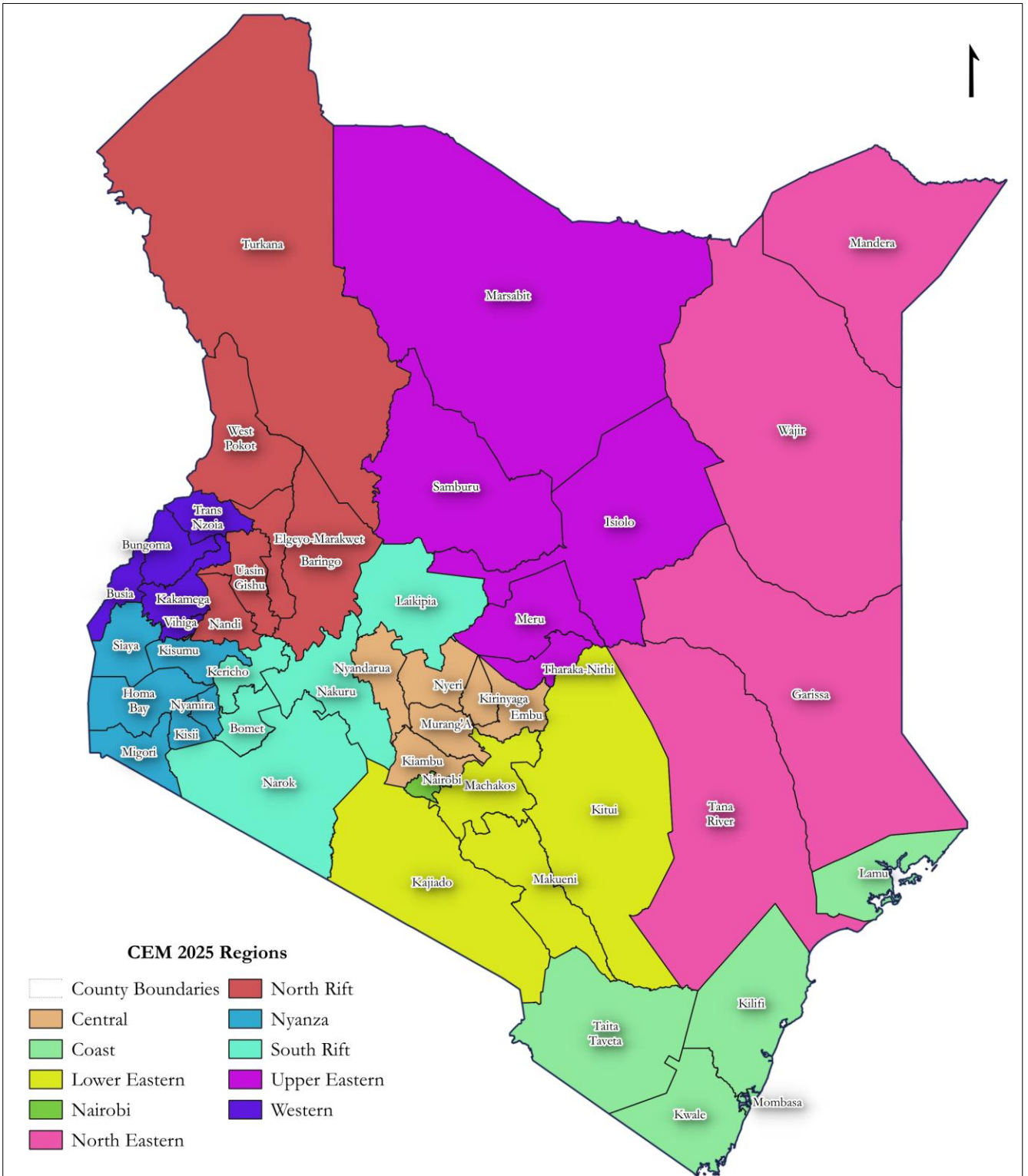

Figure 2-3 CEM 2025 Regions

Source: Consultant



### **3. Unit Rates List**

No	Work Category	Code	Work Item	Unit	Unit Price	Unit Price (indirect cost, overheads & profit included)
<b>4. Site Clearance and Topsoil Stripping</b>						
1	Bush Clearing	04.50.001	Mechanical mowing	m2	4.40	5.80
2		04.50.002	Grass cutting (manual)	m2	3.50	4.60
3		04.50.003	Heavy bush clearing	m2	16.50	21.80
4		04.50.004	Light bush clearing	m2	9.00	11.90
5		04.50.005	Pruning of tree branches	m2	98.00	129.40
6		04.50.006	Tree cutting and stump removal (200 -450 mm)	No	200.00	264.00
7		04.50.007	Tree cutting and stump removal (>450 mm)	No	1804.00	2381.30
8	Site Clearing and Backfill	04.50.008	Clearing obstructions (mechanical)	m2	37.00	48.80
9		04.50.008a	Clearing obstructions (manual)	m3	244.00	322.10
10		04.50.009	Stripping and grubbing (mechanical)	m2	106.00	139.90
11		04.50.009a	Stripping and grubbing (manual)	m2	165.00	217.80
12		04.60.001	Clearing trees, hedges, bushes, vegetation and deleterious materials (mechanical)	m2	81.00	106.90
13		04.60.001a	Clearing trees, hedges, bushes, vegetation and deleterious materials (manual)	m2	75.00	99.00
14	Concrete Demolition	04.50.010	Excavate remove & disposal of concrete structures	m3	567.00	748.40
15	Top Soil Stripping	04.80.002	Removal of overburden	m3	269.00	355.10
16	Pipe Culvert Removal	04.60.005	Removal of cracked small pipe culverts below 600mm	m	374.00	493.70
17		04.60.005a	Removal of cracked large pipe culverts above 600mm	m	564.00	744.50
<b>5. Earth Works</b>						
18	Material Filling	05.50.006	Fill in soft material and compact	m3	456.00	602.00
19		05.50.006a	Fill in soft material and compact (soil purchased)	m3	1386.00	1830.00
20		05.50.007	Fill in hard material and compact	m3	535.00	706.00
21		05.50.007a	Fill in hard material and compact (soil purchased)	m3	1489.00	1965.00
22	Material Cutting	05.50.008	Cut to spoil in soft	m3	453.00	598.00
23		05.50.008a	Cut to spoil in soft (mechanical)	m3	227.00	300.00

No	Work Category	Code	Work Item	Unit	Unit Price	Unit Price (indirect cost, overheads & profit included)
24		05.50.009	Cut to spoil in hard	m3	902.00	1191.00
25		05.50.009a	Cut to spoil in hard (mechanical)	m3	454.00	599.00
26	Concrete Demolition	05.50.012	Rock fill to swamp	m3	2939.00	3879.00
27		05.50.125	Rock fill to embankment construction	m3	3193.00	4215.00
28	Planting	05.50.014	Grassing	m2	1371.00	1810.00
29	Pipe Culvert Replacement	05.60.012	Compaction of subgrade in cut	m2	35.00	46.00
30		05.60.014	Compaction of subgrade in fill	m3	2019.00	2665.00
31		05.60.016	Compaction of original ground level	m3	42.00	55.00
31a		05.60.016a	Compaction of the 300 mm below formation level in cutting to 100% MDD (AASHTO T99)	m3	1450.00	1914.00
<b>7. Excavation and Filling for Structure</b>						
32	Material Excavation for Structures	07.50.001	Excavate for structure in soft material (manual)	m3	453.00	598.00
33		07.50.001a	Excavate for structure in soft material (mechanical)	m3	227.00	300.00
34		07.50.002	Excavate for structure in hard material (manual)	m3	902.00	1191.00
35		07.50.002a	Excavate for structure in hard material (mechanical)	m3	454.00	599.00
36	Gabion	07.70.004	Gabion Installation	m2	465.00	614.00
37		07.70.005	Rock fill to Gabions	m3	2681.00	3539.00
38	Stone Pitching	07.70.001	Stone pitching	m2	1660.00	2191.00
<b>8. Culverts and Drainage Works</b>						
39	Ditch Cleaning	08.50.002a	Ditch cleaning - mechanical	m	31.00	41.00
40		08.50.002	Ditch cleaning - manual	m	16.10	21.00
41	Culvert Cleaning	08.60.002	Small culvert cleaning-partially blocked-below 450mm	m	393.00	519.00
42		08.60.003	Medium culvert cleaning- partially blocked-600mm	m	300.00	396.00
43		08.60.004	Large culvert cleaning-partially blocked-900 mm and above	m	206.00	272.00
44		08.50.025	Manhole cleaning	No	681.00	899.00
45		08.50.016	Gulley pot cleaning	No	135.00	178.00
46		08.50.009	Covered (slotted) lined drain cleaning	m	82.00	108.00

No	Work Category	Code	Work Item	Unit	Unit Price	Unit Price (indirect cost, overheads & profit included)
47		08.50.005a	Ditch/mitre drain excavation in soft (mechanical)	m3	244.00	322.00
48		08.50.005	Ditch/mitre drain excavation in soft (manual)	m3	264.00	348.00
49		08.50.005b	Ditch/mitre drain excavation in hard (mechanical)	m3	465.00	614.00
50		08.50.005c	Ditch/mitre drain excavation in hard (manual)	m3	1331.00	1757.00
51	Pipe Culvert Installation	08.60.021	Culvert installation-300mm with surround	m	6145.00	8111.00
52		08.60.020	Culvert installation-300mm without surround	m	2513.00	3317.00
53		08.60.023	Culvert installation-450mm with surround	m	8295.00	10949.00
54		08.60.022	Culvert installation-450mm without surround	m	3137.00	4141.00
55		08.60.025	Culvert installation-600mm with surround	m	13066.00	17247.00
56		08.60.024	Culvert installation-600mm without surround	m	4313.00	5693.00
57		08.60.027	Culvert installation-900mm with surround	m	20547.00	27122.00
58		08.60.026	Culvert installation-900mm without surround	m	6166.00	8139.00
59		08.60.028	Culvert installation-1200mm with surround	m	33074.00	43658.00
60		08.60.029	Culvert installation-1200mm without surround	m	10181.00	13439.00
61		08.60.030	Excavate in soft material for culverts	m3	264.00	348.00
62		08.60.031	Excavate in hard material for culverts	m3	1331.00	1757.00
63		Headwall Construction	08.60.019	Headwall construction for 450mm pipe culvert	No	27060.59
64	08.60.019a		Headwall construction for 600mm pipe culvert	No	31557.93	41656.00
65	08.60.019b		Headwall construction for 900mm pipe culvert	No	41188.59	54369.00
66	08.60.019c		Headwall construction for 1200mm pipe culvert	No	54476.14	71909.00
67	Manhole installation	08.50.024	Manhole construction less than 1m	No	30358.00	40073.00

No	Work Category	Code	Work Item	Unit	Unit Price	Unit Price (indirect cost, overheads & profit included)
68		08.50.024a	Manhole construction more than 1m	No	49998.00	65997.00
69	Gulley Pot installation	08.50.015	Gulley pot construction	No	10575.00	13959.00
70	Drain Lining	08.50.032	Lay drain lining with concrete	m2	1970.00	2600.00
71		08.50.022a	Laying of dressed stones	m2	1959.00	2586.00
72		08.50.022	Laying of side slabs	m2	2754.00	3635.00
73		08.70.036	Laying of 300mm invert block drain	m	1796.00	2371.00
74		08.70.037	Laying of 750mm invert block drain	m	2085.00	2752.00
<b>9. Passage of Traffic</b>						
75	Traffic Control	09.50.004	Traffic Control	Day	1760.00	2323.00
76		09.50.005	Watchman	No	1696.00	2239.00
77		09.50.006	Watering	m2	13.00	17.00
<b>10. Grading and Gravelling Works</b>						
78	Grading	10.50.001	Heavy grading without watering or compaction	m2	5.10	6.70
79		10.50.002	Heavy grading with watering and compaction	m2	9.20	12.10
80		10.50.003	Light grading	m2	4.10	5.40
81		10.50.004	Reshaping	m2	13.50	17.80
82		10.50.005	Dragging	m2	13.50	17.80
83	Gravelling	10.60.001	Regravelling	m3	2174.00	2869.70
84		10.60.001a	Regravelling without watering	m3	2159.00	2849.90
<b>11. Paved Roads - Shoulder Maintenance and Repairs</b>						
85	Shoulder Rebuilding	11.50.001	Shoulder grading	m2	29.00	38.00
86		11.50.002	Shoulder repairing	m2	29.00	38.00
87	Shoulder Gravelling	11.50.003	Shoulder gravelling with natural gravel	m3	2199.00	2903.00
88		11.50.003a	Shoulder gravelling with quarry waste	m3	2676.00	3532.00
<b>12. Natural Material Base and Subbase</b>						
89	Pavement Removal	12.70.001	Scarify existing pavement to form subbase	m3	930.00	1228.00
90	Subbase/Base Rebuilding	12.50.001	Handpacked stone paving	m3	4893.00	6459.00
91		12.50.002	Provide, place and compact quarry waste	m3	5357.00	7071.00

No	Work Category	Code	Work Item	Unit	Unit Price	Unit Price (indirect cost, overheads & profit included)
92		12.50.003	Provide, place, spread and compact natural gravel	m3	2197.00	2900.00
<b>13. Graded Crushed Stone Base and Subbase</b>						
93	Graded Crushed Stone	13.50.001	Graded Crushed Stone for subbase	m3	2939.00	3879.00
94		13.60.001	Graded Crushed Stone for base	m3	2939.00	3879.00
<b>14. Cement and Lime Treated Subgrade, Subbase and Base</b>						
95	Cement/Lime Stabilization	14.50.001	Cement stabilization	m3	2758.00	3641.00
96		14.50.002	Lime stabilization	m3	4339.00	5727.00
97		14.50.003	Cement/lime mixing	m3	67.00	88.00
98		14.50.004	Curing and protection of treated layers	m2	70.30	93.00
<b>15. Bituminous Surface Treatment &amp; Surface Dressing</b>						
99	Prime Coat	15.50.002	Prime Coat (MC-30 cutback bitumen)	litre	171.00	226.00
100	Tack Coat	15.50.003	Tack Coat (grade bitumen cutback)	litre	189.00	249.00
101		15.50.003a	Tack Coat (bitumen emulsion)	litre	174.00	230.00
102	Surface Dressing	15.70.001	Seal coat	litre	260.00	343.00
103		15.60.002	Provide and roll 3/6 mm precoated chipping	m3	7466.00	9855.00
104		15.60.003	Provide and roll 6/10 mm precoated chipping	m3	7827.00	10332.00
105		15.60.004	Provide and roll 10/14 mm precoated chipping	m3	7791.00	10284.00
106		15.60.005	Provide and roll 14/20 mm precoated chipping	m3	7890.00	10415.00
<b>16. Bituminous Mixes</b>						
107a	Pavement Repairing	16.50.001a	Pothole Cutting and Cleaning	m3	1912.00	2524.00
107		16.50.001	Pothole patching - hot mix	m3	33080.00	43666.00
108		16.50.002	Pothole patching - cold mix	m3	58150.00	76758.00
109		16.50.004	Crack sealing	m	197.00	260.00
110		16.60.001	Asphalt concrete for surfacing - hot mix.	m3	33585.00	44332.00
111		16.70.001	Base repair - Dense Bitumen Macadam (DBM)	m3	29790.00	39323.00
112	Milling and Paving	16.80.010	Milling the existing bituminous layer to spoil	m3	3589.00	4737.00
113		16.80.015	Milling the existing bituminous layer for reuse	m3	12869.00	16987.00

No	Work Category	Code	Work Item	Unit	Unit Price	Unit Price (indirect cost, overheads & profit included)
17. Concrete Works						
114	Concrete Work	17.60.001	Concrete work (class 15/20)	m3	13002.00	17163.00
115		17.60.002	Concrete work (class 20/20)	m3	14264.00	18828.00
116		17.60.002a	Concrete work (class 25/20)	m3	15864.00	20940.00
117	Formwork	17.60.003	Vertical formwork class F2 finish	m2	1259.00	1662.00
118		17.60.004	Horizontal formwork class F2 finish	m2	1185.00	1564.00
119	Reinforcement	17.80.004	Reinforcement work (below 16mm)	ton	133291.00	175944.00
120		17.80.005	Reinforcement work (above 16mm)	ton	140983.00	186098.00
20. Road Furniture Repair and Maintenance						
121	Boundary posts	20.50.001	Road reserve boundary posts	No	2545.00	3359.00
122		20.50.004	Edge marker posts	No	3544.00	4678.00
123	Road Marking	20.50.007	Roads markings - white paint	m2	1199.00	1583.00
124		20.70.011	Road markings - white thermoplastic material	m2	3045.00	4019.00
124a		20.70.011a	Road markings on surface dressed pavement- white thermoplastic material	m2	3376.00	4456.00
125		20.50.006	Road markings - yellow paint	m2	1199.00	1583.00
126		20.70.010	Road markings - yellow thermoplastic material	m2	3242.00	4279.00
126a		20.70.010a	Road markings on surface dressed pavement- yellow thermoplastic material	m2	3593.00	4743.00
127		20.50.107	Road marking black paint	m2	1246.00	1645.00
128		Road Sign Erection	20.70.002	Warning signs	No	22865.00
129	20.70.005		Priority, prohibitory or mandatory signs	No	22865.00	30182.00
130	20.70.004		Standard informatory signs	No	25830.00	34096.00
131	20.70.006		Non-standard informatory signs	No	25830.00	34096.00
132	Kerb Installation	20.50.012	Kerbs	m	1843.00	2433.00
133	Kilometre marker post Installation	20.50.013	Kilometre marker posts	No	11462.00	15130.00
134	Bollard Installation	20.50.017	Concrete bollards	No	2962.00	3910.00
135		20.50.021	Steel bollards	No	1859.00	2454.00

No	Work Category	Code	Work Item	Unit	Unit Price	Unit Price (indirect cost, overheads & profit included)
136	Reflective Stud Installation	20.50.019	Reflective studs	No	928.00	1225.00
137	Microtunneling	20.60.002	Microtunneling for a 150mm diameter PVC (polyvinyl chloride) duct	m	71742.00	94699.00
138		20.60.002a	Horizontal drilling	m	44022.00	58109.00
139	Street light Installation	20.60.017	Street lighting pole (7.6m)	No	70648.00	93255.00
140		20.60.018	Street lighting pole (10m)	No	133224.00	175856.00
141		20.60.016	Street lighting control panel	No	94373.00	124572.00
142		20.60.315	Electric cable	m	1545.00	2039.00
143	Guardrail Repair	20.70.023a	Guardrail Repair Level 1	piece (4m)	6166.77	8140.00
144		20.70.023b	Guardrail Repair Level 2	piece (4m)	6933.83	9153.00
145		20.70.023c	Guardrail Repair Level 3	piece (4m)	36673.65	48409.00



# APPENDICES

## Appendix I – Work Items

# Appendix I: Work Items and Coding

No	Work Category	Code	Work Item Name	Unit	Description
<b>4. Site Clearance and Topsoil Stripping</b>					
1	Bush Clearing	04.50.001	Mechanical mowing	m <sup>2</sup>	Cut grass by machine along the side of the road or on slopes.
2		04.50.002	Grass cutting (manual)	m <sup>2</sup>	Cut grass manually along the side of the road or on slopes.
3		04.50.003	Heavy bush clearing	m <sup>2</sup>	Cut, remove and dispose bushes along the side of the road, slopes or alongside ditches.
4		04.50.004	Light bush clearing	m <sup>2</sup>	Cut grass by hand from shoulders, slopes, inlet ditches, and side ditches including back slopes, turnouts and culvert outlet.
5		04.50.005	Pruning of tree branches	m <sup>2</sup>	Cut, remove and dispose branches of trees along the side of the road, slopes or alongside ditches.
6		04.50.006	Tree cutting and stump removal (200 -450 mm)	No	Cut, remove and dispose whole trees of 200 - 450mm in girth including their stumps along the side of the road, slopes or alongside ditches.
7		04.50.007	Tree cutting and stump removal (>450 mm)	No	Cut, remove and dispose whole trees of above 450mm in girth including their stumps along the side of the road, slopes or alongside ditches.
8	Site Clearing and Backfill	04.50.008	Clearing obstructions (mechanical)	m <sup>2</sup>	Mechanically clear any obstruction including boulders and debris out of road reserve.
9		04.50.008a	Clearing obstructions (manual)	m <sup>2</sup>	Manually clear any obstruction including boulders and debris out of road reserve.
10		04.50.009	Stripping and grubbing (mechanical)	m <sup>2</sup>	Clear site on road reserve mechanically by stripping and grubbing roots.
11		04.50.009a	Stripping and grubbing (manual)	m <sup>2</sup>	Clear site on road reserve manually by stripping and grubbing roots.

No	Work Category	Code	Work Item Name	Unit	Description
12		04.60.001	Clearing trees, hedges, bushes, vegetation and deleterious materials (mechanical)	m <sup>2</sup>	Clear site on road reserve mechanically by removal of trees, hedges, bushes, vegetation and other deleterious materials.
13		04.60.001a	Clearing trees, hedges, bushes, vegetation and deleterious materials (manual)	m <sup>2</sup>	Clear site on road reserve manually by removal of trees, hedges, bushes, vegetation and other deleterious materials.
14	Concrete Demolition	04.50.010	Excavate remove & disposal of concrete structures	m <sup>2</sup>	Demolish reinforced or mass concrete structures and cart to spoil or stockpile for re-use.
15	Top Soil Stripping	04.80.002	Removal of overburden	m <sup>2</sup>	Remove topsoil to a maximum depth of 200mm.
16	Pipe Culvert Removal	04.60.005	Removal of cracked small pipe culverts below 600mm	m	Excavate, remove and dispose cracked pipe culverts below 600mm in diameter.
17		04.60.005a	Removal of cracked large pipe culverts above 600mm	m	Excavate, remove and dispose cracked pipe culverts above 600mm in diameter.
<b>5. Earth Works</b>					
18	Material Filling	05.50.006	Fill in soft material and compact	m <sup>2</sup>	Provide, place and compact soft patching material to surface defects or gravel road. It is assumed that soil to be filled is on the site or provided from cut area.
19		05.50.006a	Fill in soft material and compact (soil purchased)	m <sup>2</sup>	Provide, place and compact soft purchased patching material to surface defects or gravel road.
20		05.50.007	Fill in hard material and compact	m <sup>2</sup>	Provide, place and compact hard patching material to surface defects or gravel road. It is assumed that soil to be filled is on the site or provided from cut area.
21		05.50.007a	Fill in hard material and	m <sup>2</sup>	Provide, place and compact hard purchased patching material to surface defects or gravel road.

No	Work Category	Code	Work Item Name	Unit	Description
			compact (soil purchased)		
22	Material Cutting	05.50.008	Cut to spoil in soft	m <sup>3</sup>	Cut manually soft material to spoil
23		05.50.008a	Cut to spoil in soft (mechanical)	m <sup>3</sup>	Cut mechanically soft material to spoil
24		05.50.009	Cut to spoil in hard	m <sup>3</sup>	Cut manually hard material to spoil
25		05.50.009a	Cut to spoil in hard (mechanical)	m <sup>3</sup>	Cut mechanically hard material to spoil
26	Rock filling	05.50.012	Rock fill to swamp	m <sup>3</sup>	Manually provide and place rock fill to swamp
27		05.50.125	Rock fill to embankment construction	m <sup>3</sup>	Manually provide and place rock fill to construct embankment.
28	Planting	05.50.014	Grassing	m <sup>2</sup>	Plant grass on the slope and inverts of ditches to reduce scour effects, or on slopes to reduce soil erosion and to improve stability.
29	Pipe Culvert Replacement	05.60.012	Compaction of subgrade in cut	m <sup>2</sup>	Trim and compact.
30		05.60.014	Compaction of subgrade in fill	m <sup>2</sup>	Compaction of subgrade in fill.
31		05.60.016	Compaction of original ground level	m <sup>2</sup>	Compact the top 150 mm layer of existing ground below fills and cuts to 95% MDD (AASHTO T99)
31a		05.60.016a	Compaction of the 300 mm below formation level in cutting to 100% MDD (AASHTO T99)	m <sup>2</sup>	Compaction of the top 300mm below formation level in cuts and fills (subgrade) to 100% MDD
<b>7. Excavation and Filling for Structure</b>					
32	Material Excavation for Structures	07.50.001	Excavate for structure in soft material (manual)	m <sup>3</sup>	Excavate manually soft material for structures.
33		07.50.001a	Excavate for structure in soft material (mechanical)	m <sup>3</sup>	Excavate mechanically soft material for structures.

No	Work Category	Code	Work Item Name	Unit	Description
34		07.50.002	Excavate for structure in hard material (manual)	m□	Excavate manually in hard material for structures.
35		07.50.002a	Excavate for structure in hard material (mechanical)	m□	Excavate mechanically in hard material for structures.
36	Gabion	07.70.004	Gabion Installation	m□	Provide and place Macaferri or equivalent gabion boxes (2m * 1m * 1m).
37		07.70.005	Rock fill to Gabions	m□	Provide and place rock fill to gabions.
38	Stone Pitching	07.70.001	Stone pitching	m□	Provide stone pitching including grouting of ratio 1:4 cement to mortar.
<b>8. Culverts and Drainage Works</b>					
39	Ditch Cleaning	08.50.002a	Ditch cleaning - mechanical	m	Mechanically desilt, shape inlets outfalls, side drains to free flow conditions
40		08.50.002	Ditch cleaning - manual	m	Manually desilt, shape inlets outfalls, side drains to free flow conditions.
41	Culvert Cleaning	08.60.002	Small culvert cleaning-partially blocked-below 450mm	m	Clean culverts of below 450mm in diameter to free flow conditions
42		08.60.003	Medium culvert cleaning-partially blocked-600mm	m	Clean culverts of 600mm in diameter to free flow conditions
43		08.60.004	Large culvert cleaning-partially blocked-900 mm and above	m	Clean culverts of 900mm and above in diameter to free flow conditions
44		08.50.025	Manhole cleaning	No	Remove all silt and debris and wash out manhole to free flow conditions.
45		08.50.016	Gulley pot cleaning	No	Clean siltation and debris from gulley pot to good impoundment conditions.
46		08.50.009	Covered (slotted) lined drain cleaning	m	Remove all silt and debris and wash out covered lined drain to free flow conditions
47		08.50.005a	Ditch/mitre drain excavation in soft (mechanical)	m□	Excavate mechanically for inlet, outfall, mitre and catchwater drains in soft material

No	Work Category	Code	Work Item Name	Unit	Description
48		08.50.005	Ditch/mitre drain excavation in soft (manual)	m <sup>2</sup>	Excavate manually for inlet, outfall, mitre and catchwater drains in soft material
49		08.50.005b	Ditch/mitre drain excavation in hard (mechanical)	m <sup>2</sup>	Excavate mechanically in hard material for inlet, outfall, mitre and catchwater drains.
50		08.50.005c	Ditch/mitre drain excavation in hard (manual)	m <sup>2</sup>	Excavate manually in hard material for inlet, outfall, mitre and catchwater drains
51	Pipe Culvert Installation	08.60.021	Culvert installation-300mm with surround	m	Provide, lay and joint pipe culvert of 300mm in diameter with surround
52		08.60.020	Culvert installation-300mm without surround	m	Provide, lay and joint unhounded pipe culvert of 300mm in diameter without surround
53		08.60.023	Culvert installation-450mm with surround	m	Provide, lay and joint pipe culvert of 450mm in diameter with surround.
54		08.60.022	Culvert installation-450mm without surround	m	Provide, lay and joint pipe culvert of 450mm in diameter without surround.
55		08.60.025	Culvert installation-600mm with surround	m	Provide, lay and joint pipe culvert of 600mm in diameter with surround
56		08.60.024	Culvert installation-600mm without surround	m	Provide, lay and joint pipe culvert of 600mm in diameter without surround
57		08.60.027	Culvert installation-900mm with surround	m	Provide, lay and joint pipe culvert of 900mm in diameter with surround.
58		08.60.026	Culvert installation-900mm without surround	m	Provide, lay and joint pipe culvert of 900mm in diameter without surround
59		08.60.028	Culvert installation-1200mm with surround	m	Provide, lay and joint pipe culvert of 1200mm in diameter with surround

No	Work Category	Code	Work Item Name	Unit	Description
60		08.60.029	Culvert installation- 1200mm without surround	m	Provide, lay and joint culvert of 1200mm in diameter without surround
61		08.60.030	Excavate in soft material for culverts	m <sup>3</sup>	Excavation manually in soft material for culvert in any size.
62		08.60.031	Excavate in hard material for culverts	m <sup>3</sup>	Excavation manually in hard material for culvert in any size.
63	Headwall Construction	08.60.019	Headwall construction for 450mm pipe culvert	No	Reconstruct or repair damaged headwall (wingwall and apron) for 450mm pipe culvert to prevent the collapse and the potential slippage of the material and pavement above the culvert.
64		08.60.019a	Headwall construction for 600mm pipe culvert	No	Reconstruct or repair damaged headwall (wingwall and apron) for 600mm pipe culvert to prevent the collapse and the potential slip of the material and pavement above the culvert.
65		08.60.019b	Headwall construction for 900mm pipe culvert	No	Reconstruct or repair damaged headwall (wingwall and apron) for 900mm pipe culvert to prevent the collapse and the potential slip of the material and pavement above the culvert.
66		08.60.019c	Headwall construction for 1200mm pipe culvert	No	Reconstruct or repair damaged headwall (wingwall and apron) for 1200mm pipe culvert to prevent the collapse and the potential slip of the material and pavement above the culvert.
67	Manhole installation	08.50.024	Manhole construction less than 1m	No	Install new small manhole of less than 1m in depth (900-1200mm in inner diameter)
68		08.50.024a	Manhole construction more than 1m	No	Install new large manhole of more than 1m in depth (900-1200mm in inner diameter)
69	Gulley Pot installation	08.50.015	Gulley pot construction	No	Provide and place gulley pots including grating (H=900mm) for inlet structures as directed by the Engineer.



No	Work Category	Code	Work Item Name	Unit	Description
70	Drain Lining	08.50.032	Lay drain lining with concrete	m□	Place concrete lining to the slopes and invert of the ditch to prevent the scour.
71		08.50.022a	Laying of dressed stones	m□	Place dressed stone lining to the slopes and invert of the ditch to prevent the scour.
72		08.50.022	Laying of side slabs	m□	Place side slab lining to the slopes and invert of the ditch to prevent the scour.
73		08.70.036	Laying of 300mm invert block drain	m	Provide, lay and joint invert block drain of 300mm in diameter
74		08.70.037	Laying of 750mm invert block drain	m	Provide, lay and joint invert block drain of 750mm in width
<b>9. Passage of Traffic</b>					
75	Traffic Control	09.50.004	Traffic Control	Day	Place warning signs, barriers and cones around the working lane on the carriageway and guide the passage of traffic through the works
76		09.50.005	Watchman	No	Provide watchman for all round surveillance.
77		09.50.006	Watering	m□	Sprinkle water to control dust for passage of traffic through the works or compaction at earth works
<b>10. Grading and Graveling Works</b>					
78	Grading	10.50.001	Heavy grading without watering or compaction	m□	Trim with Motor Grader or heavy towed grader existing carriageway surface to camber, including slopes and ditches without providing watering and compaction
79		10.50.002	Heavy grading with watering and compaction	m□	Trim with Motor Grader or heavy towed grader existing carriageway surface to camber, including slopes and ditches providing watering and compaction
80		10.50.003	Light grading	m□	Trim with motor grader existing carriageway to camber, including slopes and ditches.
81		10.50.004	Reshaping	m□	Restore manually the camber on earth or gravel roads by returning

No	Work Category	Code	Work Item Name	Unit	Description
					material from road sides and shoulder toward road centre.
82		10.50.005	Dragging	m <sup>2</sup>	Remove manually loose material from the surface to delay the formation of corrugations
83	Gravelling	10.60.001	Regravelling	m <sup>2</sup>	Prepare for road formation and provide, place spread, shape and compact with watering gravel of not less than CBR 20%
84		10.60.001a	Regravelling without watering	m <sup>2</sup>	Prepare for road formation and provide, place spread, shape and compact without watering gravel of not less than CBR 20%
<b>11. Paved Roads - Shoulder Maintenance and Repairs</b>					
85	Shoulder Rebuilding	11.50.001	Shoulder grading	m <sup>2</sup>	Prepare surface of existing shoulders, accesses and bus bays, including benching where necessary, water process and compact
86		11.50.002	Shoulder repairing	m <sup>2</sup>	Prepare surface of existing shoulders, accesses and bus bays, water process and compact
87	Shoulder Gravelling	11.50.003	Shoulder gravelling with natural gravel	m <sup>2</sup>	Provide, place, spread, shape and compact 150mm of natural gravel of CBR 30% to shoulders, accesses and bus bays
88		11.50.003a	Shoulder gravelling with quarry waste	m <sup>2</sup>	Provide, place and compact quarry waste material to shoulders, accesses and bus bays
<b>12. Natural Material Base and Subbase</b>					
89	Pavement Removal	12.70.001	Scarify existing pavement to form subbase	m <sup>2</sup>	Break or scarify mechanically the existing pavement layer, and compact.
90	Subbase/Base Rebuilding	12.50.001	Handpacked stone paving	m <sup>2</sup>	Provide, lay, and compact hand packed stone material including filling of voids with stone dust
91		12.50.002	Provide, place and compact quarry waste	m <sup>2</sup>	Provide, spread, shape and compact approved quarry waste of CBR 30% and above for 5cm in thickness.
92		12.50.003	Provide, place, spread and	m <sup>2</sup>	Provide, spread, shape and compact approved natural gravel

No	Work Category	Code	Work Item Name	Unit	Description
			compact natural gravel		of CBR 30% and above for 15cm in thickness.
<b>13. Graded Crushed Stone Base and Subbase</b>					
93	Graded Crushed Stone	13.50.001	Graded Crushed Stone for subbase	m <sup>2</sup>	Provide, place and spread approved graded crushed stone for subbase.
94		13.60.001	Graded Crushed Stone for base	m <sup>2</sup>	Provide, place and spread approved graded crushed stone for base.
<b>14. Cement and Lime Treated Subgrade, Subbase and Base</b>					
95	Cement/Lime Stabilization	14.50.001	Cement stabilization	m <sup>2</sup>	Provide, spread cement on natural gravel or graded crushed stone
96		14.50.002	Lime stabilization	m <sup>2</sup>	Provide, spread lime on natural gravel or graded crushed stone
97		14.50.003	Cement/lime mixing	m <sup>2</sup>	Mixing in cement/lime into natural gravel or graded crushed stone
98		14.50.004	Curing and protection of treated layers	m <sup>2</sup>	Cure and protect layers treated with cement or lime stabilizers
<b>15. Bituminous Surface Treatment &amp; Surface Dressing</b>					
99	Prime Coat	15.50.002	Prime Coat (MC-30 cutback bitumen)	litre	Prepare surface of carriageway, bus bays and repair areas, provide and spray MC-30 cutback bitumen at a rate of 0.8-1.2 litre/m <sup>2</sup> as prime coat
100	Tack Coat	15.50.003	Tack Coat (grade bitumen cutback)	litre	Prepare surface of carriageway and bus bays, provide and spray 80/100 penetration grade bitumen cut back using 5-15% kerosene as tack coat for asphalt concrete wearing course at a spray rate of 0.5-0.7 litre/m <sup>2</sup>
101		15.50.003a	Tack Coat (bitumen emulsion)	litre	Prepare surface of repair areas provide and spray KI-60 bitumen emulsion as tack coat or seal to repair areas at a spray rate of 0.8-1.0 litre/m <sup>2</sup>
102	Surface Dressing	15.70.001	Seal coat	litre	Cover a large worn surface area with aggregate distributed over spread bitumen to seal cracks and to recover adequate surface texture

No	Work Category	Code	Work Item Name	Unit	Description
103		15.60.002	Provide and roll 3/6 mm precoated chipping	m <sup>2</sup>	Treat worn surface with graded aggregates of 3 to 6mm precoated with bitumen to recover adequate surface texture
104		15.60.003	Provide and roll 6/10 mm precoated chipping	m <sup>2</sup>	Treat worn surface with graded aggregates of 6 to 10mm precoated with bitumen to recover adequate surface texture
105		15.60.004	Provide and roll 10/14 mm precoated chipping	m <sup>2</sup>	Treat worn surface with graded aggregates of 10 to 14mm precoated with bitumen to recover adequate surface texture
106		15.60.005	Provide and roll 14/20 mm precoated chipping	m <sup>2</sup>	Treat worn surface with graded aggregates of 14 to 20mm precoated with bitumen to recover adequate surface texture
<b>16. Bituminous Mixes</b>					
107a	Pavement Repairing	16.50.001a	Pothole Cutting and Cleaning	m <sup>2</sup>	Trim, cut and clean failed bituminous surface
107		16.50.001	Pothole patching - hot mix	m <sup>2</sup>	Provide, place and compact asphaltic concrete to repair areas and for regulation to carriageway
108		16.50.002	Pothole patching - cold mix	m <sup>2</sup>	Repair defects on bituminous surface by cold bituminous mixture
109		16.50.004	Crack sealing	m	Repair transverse or longitudinal cracking on surface dressed or asphalt concrete
110		16.60.001	Asphalt concrete for surfacing - hot mix.	m <sup>2</sup>	Overlay or continuously repave surface by hot bituminous mixture
111		16.70.001	Base repair - Dense Bitumen Macadam (DBM)	m <sup>2</sup>	Place dense bitumen macadam for base material and roll
112	Milling and Paving	16.80.010	Milling the existing bituminous layer to spoil	m <sup>2</sup>	Mill mechanically the existing bituminous layer to spoil
113		16.80.015	Milling the existing bituminous layer for reuse	m <sup>2</sup>	Mill mechanically the existing bituminous layer and stockpile for reuse or recycle
<b>17. Concrete Works</b>					

No	Work Category	Code	Work Item Name	Unit	Description
114	Concrete Work	17.60.001	Concrete work (class 15/20)	m <sup>3</sup>	Provide, place and compact class 15/20 concrete mixture for blinding.
115		17.60.002	Concrete work (class 20/20)	m <sup>3</sup>	Provide, place and compact class 20/20 concrete mixture.
116		17.60.002a	Concrete work (class 25/20)	m <sup>3</sup>	Provide, place and compact class 25/20 concrete mixture.
117	Formwork	17.60.003	Vertical formwork class F2 finish	m <sup>2</sup>	Provide and erect formwork of class F2 finish to the vertical direction
118		17.60.004	Horizontal formwork class F2 finish	m <sup>2</sup>	Provide and erect formwork of class F2 finish to the horizontal direction
119	Reinforcement	17.80.004	Reinforcement work (below 16mm)	ton	Provide, cut bend and fix into position high yield reinforcement bar below 16mm
120		17.80.005	Reinforcement work (above 16mm)	ton	Provide, cut bend and fix into position high yield reinforcement bar above 16mm
<b>20. Road Furniture Repair and Maintenance</b>					
121	Boundary posts	20.50.001	Road reserve boundary posts	No	Provide and erect road reserve boundary posts (size 1.2 x 0.2 x 0.2)
122		20.50.004	Edge marker posts	No	Provide and erect edge marker posts
123	Road Marking	20.50.007	Road markings - white paint	m <sup>2</sup>	Provide reflectorized white paint for road markings (w = 10cm)
124		20.70.011	Road markings - white thermoplastic material	m <sup>2</sup>	Renew faded or missing white road markings (w = 10cm) with thermoplastic material
124a		20.70.011a	Road markings on surface dressed pavement- white thermoplastic material	m <sup>2</sup>	Renew faded or missing white road markings on surface dressed pavement (w = 10cm) with thermoplastic material
125		20.50.006	Road markings - yellow paint	m <sup>2</sup>	Provide reflectorized yellow paint for road markings (w = 10cm)
126		20.70.010	Road markings - yellow thermoplastic material	m <sup>2</sup>	Upgrade faded or missing yellow road markings (w = 10cm) with thermoplastic material

No	Work Category	Code	Work Item Name	Unit	Description
12 6a		20.70.010a	Road markings on surface dressed pavement- yellow thermoplastic material	m <sup>2</sup>	Renew faded or missing yellow road markings on surface dressed pavement (w = 10cm) with thermoplastic material
12 7		20.50.107	Road marking black paint	m <sup>2</sup>	Provide reflectorized black paint for road markings (w = 10cm)
12 8	Road Sign Erection	20.70.002	Warning signs	No	Provide and erect priority, prohibitory or mandatory signs
12 9		20.70.005	Priority, prohibitory or mandatory signs	No	Priority, prohibitory or mandatory signs
13 0		20.70.004	Standard informatory signs	No	Provide and erect informatory signs
13 1		20.70.006	Non-standard informatory signs	No	Provide and erect non-standard warning signs
13 2	Kerb Installation	20.50.012	Kerbs	m	Provide lay and joint concrete class 20/20 kerbs in support to carriageway, bus bays and junctions
13 3	Kilometre marker post Installation	20.50.013	Kilometre marker posts	No	Kilometre marker post Installation.
13 4	Bollard Installation	20.50.017	Concrete bollards	No	Concrete bollard Installation (diameter 0.2m, length 0.9m, embedded depth 0.45m)
13 5		20.50.021	Steel bollards	No	Place and provide gauge 16 steel pipe Bollards of diameter 150 mm and 1.05m above the ground embedded to a depth of 0.45m at place
13 6	Reflective Stud Installation	20.50.019	Reflective studs	No	Install reflective studs along the centre line
13 7	Microtunneling	20.60.002	Microtunneling for a 150mm diameter PVC (polyvinyl chloride) duct	m	Conduct microtunneling with a 150mm dia. PVC duct (under silt or sand condition)
13 8		20.60.002a	Horizontal drilling	m	Conduct horizontal drilling for 150mm hole in diameter (under gravel condition)
13 9	Street light Installation	20.60.017	Street lighting pole (7.6m)	No	Provide and install 7.6m street lighting pole including cables accessories and lamp.

No	Work Category	Code	Work Item Name	Unit	Description
140		20.60.018	Street lighting pole (10m)	No	Provide and install 10.0m street lighting pole including cables accessories and lamp.
141		20.60.016	Street lighting control panel	No	Provide and install 10.0m street lighting pole including cables accessories and lamp.
142		20.60.315	Electric cable	m	Provide and install supply cables between the street lighting poles.
143	Guardrail Repair	20.70.023a	Guardrail Repair Level 1	piece (4m)	Removal of damaged guardrail and replacement with straightened beam
144		20.70.023b	Guardrail Repair Level 2	piece (4m)	Removal of damaged guardrail, replacement with a straightened beam and realignment of posts
145		20.70.023c	Guardrail Repair Level 3	piece (4m)	Complete removal of damaged guardrail beam and installation with new beam, posts and spacers

## Appendix 2 – Price List



Price List (Labour, Machinery, Material)

Upper Eastern

<b>Legend</b>	a	Refer to official price index
	b	Refer to recent market price (surveyed by Cost Surveyors)
	c	Provisional price

No	Item	Code	Name	Type	Unit	Unit Price 2025	Source 2025	
1	Labour (South Rift Region)	22.50.001	Support Staff		Person Day	712	Wage Order 2024	a
		22.50.002	Unskilled labour		Person Day	712	Wage Order 2024	a
		22.50.005	Artisans G2		Person Day	1,211	Wage Order 2024	a
		22.50.007	Skilled Labour: Overseer		Person Day	1,467	Wage Order 2024	a
		22.50.101	Skilled Labour: Operator		Person Day	1,647	Wage Order 2024	a
2	Machinery	22.61.101	Truck Flat bed : 2.5 - 5 Tonnes		Hour	1,990	MTD Hire Rate	a
		22.61.102	Truck with crane	4t	Hour	2,723	2025 March Market rate	b
		22.62.015	Water Tanker : 6000 - 8000 Lt.		Hour	1,780	MTD Hire Rate	a
		22.63.012	Motor Grader (e.g. CAT 112F): 100 - 130 HP		Hour	4,180	MTD Hire Rate	a
		22.63.101	Bulldozer	BD65EX	Hour	7,440	MTD Hire Rate	a
		22.63.102	Excavator	130-150hp	Hour	6,530	MTD Hire Rate	a
		22.63.103	Backhoe loader	130-150hp	Hour	5,343	2025 March Market rate	b
		22.64.001	Pedestrian Roller : 700 - 1000 Kg.		Hour	1,150	MTD Hire Rate	a
		22.64.004	Single drum steel Vibrator roller: 9-10T, 130 HP		Hour	3,126	2025 March Market rate	b
		22.64.005	Pneumatic Roller: 10T, 130HP		Hour	3,650	MTD Hire Rate	a
		22.65.008	Road Marking Machine		Hour	570	MTD Hire Rate	a
		22.65.101	Melting pod (for paint)	200 - 350kg	Hour	3,168	2025 March Market rate	b
		22.67.001	Grass cutter	150cm, 35hp	Hour	120	MTD Hire Rate	a
		22.67.004	Bitumen Sprayer H/Operated	200L	Hour	410	MTD Hire Rate	a
		22.67.005	Vibrator P/Tamper		Hour	400	MTD Hire Rate	a
		22.67.101	Milling machine	197hp	Hour	3,489	2025 March Market rate	b
		22.67.102	Resurface machine	120hp	Hour	30,345	2025 March Market rate	b
		22.67.103	Road heater	63hp	Hour	27,038	Nairobi 2025 Rate	b
		22.67.104	Asphalt finisher	37H	Hour	7,198	2025 March Market rate	b
		22.67.105	Power suction car	4t	Hour	9,550	Nairobi 2025 Rate	b
22.67.106	Muddy water processing machine		Day	53,778	2025 March Market rate	b		
22.67.107	Boring machine	81kw	Day	60,000	2025 March Market rate	b		
22.67.108	Air compressor	150CFM, 4250LPM	Day	4,600	MTD Hire Rate	a		
22.67.109	Asphalt/Bitumen cutter		Hour	1,438	2025 March Market rate	b		
22.67.110	Chip spreader		Hour	6,207	2025 March Market rate	b		
3	Material	22.69.009	Fine aggregates(sand)		m3	2,135	2025 March Market rate	b
		22.70.001	Fine aggregates(stone dust)		m3	2,493	2025 March Market rate	b
		22.70.002	Graded aggregates (ballast)		m3	2,351	2025 March Market rate	b
		22.70.003	water		m3	575	2025 March Market rate	b
		22.70.004	Cement (ordinary portland)		Kg	15	2025 March Market rate	b
		22.70.006	Hydrated lime		Kg	28	2025 March Market rate	b
		22.71.012	Square twisted bars 16mm		t	105,955	2025 March Market rate	b
		22.72.001	Precast concrete culvert - 450mm		m	2,256	2025 March Market rate	b
		22.72.002	Precast concrete culvert - 600mm		m	3,186	2025 March Market rate	b
		22.72.003	Precast concrete culvert - 900mm		m	4,599	2025 March Market rate	b
		22.72.004	Precast concrete culvert - 1200mm		m	7,957	2025 March Market rate	b
		22.72.016	Coarse aggregates(chippings) - 3/6mm		m3	2,003	2025 March Market rate	b
		22.72.017	Coarse aggregates(chippings) - 6/10mm		m3	2,315	2025 March Market rate	b
		22.72.018	Coarse aggregates(chippings) - 10/14mm		m3	2,502	2025 March Market rate	b
		22.72.019	Coarse aggregates(chippings) - 14/20mm		m3	2,588	2025 March Market rate	b
		22.72.020	Stone dust		m3	1,939	2025 March Market rate	b
		22.72.021	Gravel material (murrum)		m3	1,580	2025 March Market rate	b
		22.72.022	Hardcore		m3	1,728	2025 March Market rate	b
		22.72.023	Crusher run material (Graded crushed stone)		m3	2,169	2025 March Market rate	b
		22.72.024	Quarry waste material		m3	1,851	2025 March Market rate	b
		22.72.101	Precast concrete culvert - 300mm		m	1,767	2025 March Market rate	b
		22.72.102	Stone		m3	1,728	2025 March Market rate	b
		22.72.103	Gully pot with grating		Set	12,814	Nairobi 2025 Rate +Haulage	b
		22.72.104	Invert block drain	600*330*355	No.	675	2025 March Market rate	b
		22.72.105	Invert block drain	600*760*190	No.	733	2025 March Market rate	b
		22.72.106	Side Slab concrete block	3**9**24"	No.	234	2025 March Market rate	b
		22.72.107	Manhole cover slab	1220*150	No.	6,102	Nairobi 2025 Rate +Haulage	b
		22.72.108	Soil (soft)		m3	738	2025 March Market rate	b
		22.72.109	Soil (hard)		m3	757	2025 March Market rate	b
		22.73.002	Premix - AC Type I (cold)		m3	57,429	Nairobi 2025 Rate +Haulage	b
22.73.003	Premix - AC Type I (hot)		m3	25,699	2025 March Market rate	b		
22.73.004	Dense Bitumen Macadam		m3	22,414	2025 March Market rate	b		
22.73.006	Bituminous sealant (K-160)		m3	115,661	2025 March Market rate	b		
22.73.012	MC 30 Bitumen		litre	124	2025 March Market rate	b		
22.73.013	80/100 Pen grade bitumen		litre	138	2025 March Market rate	b		
22.74.002	Fuel		litre	147	EPPRA	a		
22.77.001	Mesh wire 8' x 4' gauge 18		m2	959	2025 March Market rate	b		
22.77.101	Gabion mesh	2m*1m = 2m2	No.	3,819	2025 March Market rate	b		
22.77.102	Gabion Mattress	10mm	m2	3,725	2025 March Market rate	b		
22.77.103	Flat metal plate	1/16-1/18	m2	1,166	2025 March Market rate	b		
22.77.104	Steel pipe	2inch	m	766	2025 March Market rate	b		

No	Item	Code	Name	Type	Unit	Unit Price 2025	Source 2025	
3	Material	22.77.105	Bolts with nuts	8cm	Set	291	2025 March Market rate	b
		22.77.106	Brackets		No	196	2025 March Market rate	b
		22.77.107	Steel angle	125*5mm	kg	534	2025 March Market rate	b
		22.77.108	Steel plate	450*3mm	kg	214	2025 March Market rate	b
		22.77.109	Steel bollard	SGP. 5B. 125A	kg	667	2025 March Market rate	b
		22.77.110	Mesh wire	A142	m2	282	2025 March Market rate	b
		22.77.111	Cast iron manhole cover	600*450 heavy duty with frame	No.	4,504	2025 March Market rate	b
		22.78.101	Cypress	for fixed deck	m3	71,452	2025 March Market rate	b
		22.78.102	Wooden formwork panel		m2	841	2025 March Market rate	b
		22.79.003	Road marking paint yellow		litre	833	2025 March Market rate	b
		22.79.004	Road marking paint white		litre	817	2025 March Market rate	b
		22.79.005	Thermoplastic paint yellow	premixed with primer and glass beads	Kg	454	Nairobi 2025 Rate +Haulage	b
		22.79.006	Thermoplastic paint white	premixed with primer and glass beads	Kg	426	Nairobi 2025 Rate +Haulage	b
		22.79.012	Reflective 'cat' eyes		No	830	2025 March Market rate	b
		22.79.013	Reflective mark posts	White PVC post 1400	No.	3,103	2025 March Market rate	b
		22.79.101	Road marking paint black		litre	854	2025 March Market rate	b
		22.79.104	Reflective paint		litre	862	2025 March Market rate	b
		22.79.105	White paint		litre	655	2025 March Market rate	b
		22.79.106	Black paint		litre	670	2025 March Market rate	b
		22.79.107	Road Kerb	12.25*24.5	No.	477	2025 March Market rate	b
		22.79.108	Road channel	9.8*12.25	No.	333	2025 March Market rate	b
		22.79.109	Duct Pipe (PVC150)		m	592	2025 March Market rate	b
		22.79.110	Equipment for lead pipe jacking	196kN	Day	32,117	Nairobi 2025 Rate	b
		22.79.111	Equipment for lead pipe jacking (fixing part)		Day	1,444	Nairobi 2025 Rate	b
		22.79.112	Equipment for lead pipe jacking (moving part)		m	210	Nairobi 2025 Rate +Haulage	b
		22.79.113	Equipment for Underground pipe jacking	196kN	Day	19,995	Nairobi 2025 Rate	b
		22.79.114	Equipment for Underground pipe jacking (fixing part)		Day	12,879	Nairobi 2025 Rate	b
		22.79.115	Equipment for Underground pipe jacking (moving part)		m	9,720	Nairobi 2025 Rate +Haulage	b
		22.79.116	Water stopper		No.	2,421	Nairobi 2025 Rate +Haulage	b
		22.79.117	Concrete anchor		No.	249	Nairobi 2025 Rate +Haulage	b
		22.79.118	Water stop cement		Kg	180	2025 March Market rate	b
		22.79.119	Aggregation(jacking)		kg	13	2025 March Market rate	b
		22.79.120	Aggregation(washing)		kg	12	2025 March Market rate	b
		22.79.121	Shank-rod	90mm	No.	298,125	Nairobi 2025 Rate +Haulage	b
22.79.122	Driving-adapter		No.	1,593	Nairobi 2025 Rate +Haulage	b		
22.79.123	drilling-pipe		No.	51,495	Nairobi 2025 Rate +Haulage	b		
22.79.124	Ring-bit		No.	101,418	Nairobi 2025 Rate +Haulage	b		
22.79.125	Water-swivel		No.	95,412	Nairobi 2025 Rate +Haulage	b		
22.79.126	Cutter-set		No.	45,798	Nairobi 2025 Rate +Haulage	b		
22.79.127	Core-tube		No.	46,480	Nairobi 2025 Rate +Haulage	b		
22.79.128	Magnifying-bit		No.	508,042	Nairobi 2025 Rate +Haulage	b		
22.79.129	Earth bar	10*1500mm	No.	803	2025 March Market rate	b		
22.79.130	Lighting pole	7.6m	No.	27,087	Nairobi 2025 Rate +Haulage	b		
22.79.131	Lighting pole	10.0m	No.	78,169	Nairobi 2025 Rate +Haulage	b		
22.79.132	Cable	for light	m	243	2025 March Market rate	b		
22.79.133	Accessories	for light	Set	6,716	2025 March Market rate	b		
22.79.134	Lamp		No.	14,944	Nairobi 2025 Rate +Haulage	b		
22.79.135	Control panel		No.	37,636	Nairobi 2025 Rate +Haulage	b		
22.79.136	Cable	for control panel	m	1,208	Nairobi 2025 Rate +Haulage	b		
22.79.137	Accessories	for control panel	Set	40,861	Nairobi 2025 Rate +Haulage	b		
22.79.138	Meter		No.	3,772	2025 March Market rate	b		
22.79.139	Grass		m2	862	2025 March Market rate	b		
22.79.140	Red soil		m3	2,637	2025 March Market rate	b		
22.79.141	Manure		m3	6,384	Nairobi 2025 Rate +Haulage	b		
22.79.142	Warning triangular sign	600mm	No.	14,546	Nairobi 2025 Rate +Haulage	b		
22.79.143	Priority triangular sign	600mm	No.	14,546	Nairobi 2025 Rate +Haulage	b		
22.79.144	Standard informatory sign		No.	17,241	2025 March Market rate	b		
22.79.145	Non-standard informatory sign	less than 1m2	No.	17,241	2025 March Market rate	b		
22.79.150	Guardrail Beam	4m	No.	11,713	Nairobi 2025 Rate +Haulage	b		
22.79.151	Guardrail Post	140 mm dia, 6 gauge	m	4,793	Nairobi 2025 Rate +Haulage	b		
22.79.152	Bolts with nuts and washers (short)		No.	173	2025 March Market rate	b		
22.79.153	Bolts with nuts and washers (long)		No.	258	2025 March Market rate	b		
22.79.154	Fuel	Petrol	litre	155	EPPRA	a		
22.79.155	Pick up truck		day	10,880	2025 March Market rate	b		
22.79.156	Truck	2 ton	day	17,737	2025 March Market rate	b		
22.79.157	Thinner		litre	434	2025 March Market rate	b		
22.79.158	Cement (OPC)		kg	15	2025 March Market rate	b		
22.79.159	Pulveriser		Hour	5,022	2025 March Market rate	b		
22.79.160	Hessian cloth		m2	222	2025 March Market rate	b		
22.79.161	K-160		litre	116	2025 March Market rate	b		
22.79.162	Reflecting Glass Beads		kg	214	2025 March Market rate	b		
22.79.163	Electricity		Kw/h	29	KPLC	a		
22.79.164	Beam Straightener		Hour	11,586	2025 March Market rate	b		